

Anti-corrosion pressure gauge

Model: P870 series

Spec. sheet no. PD08-07

Service intended

P870 series provide a superior chemical resistant and non-viscous pressure gauge which employs fluorine resin for the wetted parts. It can be used with highly corrosive fluids. The case material is PP resin and resistance to corrosive environments.

EAC

Nominal diameter

50 mm

Accuracy

±1.5 % of full scale (Only available with 0.6 and 1 MPa)
±2.0 % of full scale

Scale range (MPa, kPa, bar)

0 ~ 0.1 MPa to 0 ~ 1 MPa

Working pressure

Steady pressure : 75 % of full scale

Working temperature limits

Ambient : 10 ~ 30 °C

Fluid

Max. 150 °C

Degree of protection

For using indoor

Temperature effect

Accuracy at temperature above and below the reference temperature (20 °C) will be effected by approximately ±0.8 % per 10 °C of full scale



Standard features

Pressure connection

Fluorine resin (PTFE, PFA)

Dial

White aluminium with black graduations

Element

Bellows : Fluorine resin (PFA)

Pointer

Black painted aluminium alloy

Case and cover

PP resin

Process connection

3/8" PT, PF, tube (please consult about other connection)

Window

Screw type PET resin

Treatment

Assembly and adjustment : Clean room (Class 10,000)

Leak test : N₂ gas leak test

Treatment : Use no oil and water

Packing : after N₂ gas flushing, clean polyethylene hermetical sealed packaging

Movement

Brass

WISE[®]

I P870_01

1. Base model**P870** Anti-corrosion pressure gauge**2. Nominal diameter****1** 50 mm**3. Type of mounting****A** Bottom connection, direct**4. Accuracy****4** ±1.5 % of full scale (Only available with 0.6 and 1 MPa)**5** ±2.0 % of full scale**5. Connection type****D3** PF 3/8"**D8** PT 3/8"**TA** Tube 1/4" x 1/32"**TB** Tube 3/8" x 1/4"**TC** Tube 1/2" x 3/8"**TN** Tube 6 mm x 4 mm**TM** Tube 8 mm x 6 mm**EE** 1/2" UNF**6. Unit****H** bar**I** MPa**J** kPa**7. Range****XXX** Refer to pressure range table**8. Dial color****3** 2 colors**9. Option****0** None**1** Accessories

1	2	3	4	5	6	7	8
P870	1	A	4	D8	XXX	4	0

**Sample
ordering code**

P870 : Type of mounting

Code : D

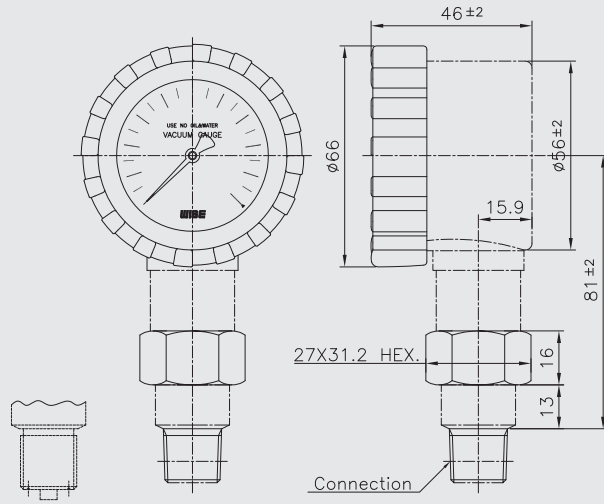

Code : T

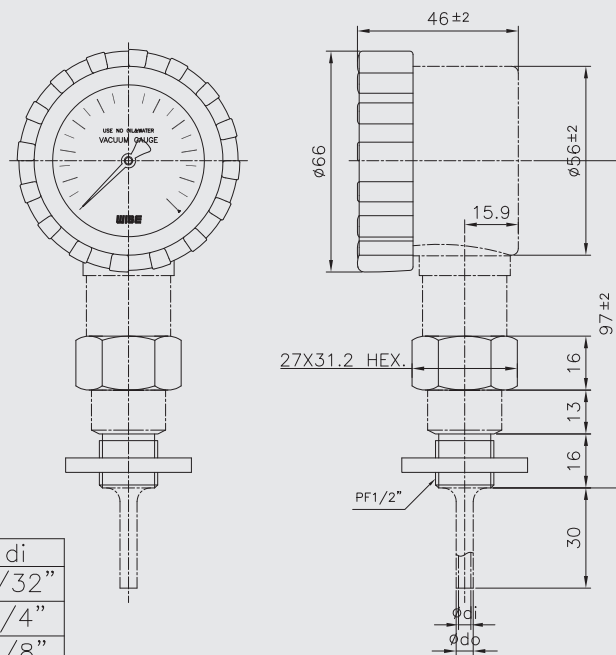

Code NO.	do	di
TA	1/4"	5/32"
TB	3/8"	1/4"
TC	1/2"	3/8"
TN	6	4
TM	8	6

Pressure unit and range table

Range and code	Unit and code			Accuracy
	H : bar	I : MPa	J : kPa	
026	-1 ~ 0	-0.1 ~ 0	-100 ~ 0	2.0 %
041	0 ~ 1	0 ~ 0.1	0 ~ 100	
042	0 ~ 2	0 ~ 0.2	0 ~ 200	
044	0 ~ 4	0 ~ 0.4	0 ~ 400	
045	0 ~ 6	0 ~ 0.6	0 ~ 600	1.5 %
047	0 ~ 10	0 ~ 1	0 ~ 1,000	