

Dead weight tester (Up to 10 MPa)

Model: P910, P911 series

Spec. sheet no. PD09-01

Service intended

These series are designed to be used for gauge calibration. Operating range of these series is available up to 10 Mpa. It is designed to perform the tasks such as setting, testing, and repairing pressure measurement.

EAC

Dimensions

Base 186 mm (W) x 275 mm (H) x 286 mm (D)
Excluding hand wheel

Color

Black



Reservoir

These series have a centrally isolated mounting valve and a transparent cover which can be sealed in order that tester is moved without oil leakage.

Screw pump

The use of a large diameter ram eliminates the need for a priming pump.

Accuracy

0.04 %

Piston cylinder unit

The tester is fitted with an oil reservoir, this is linked to the piston cylinder unit. A stop valve is provided to prevent excessive pressure driving the piston out of the cylinder.

WISE[®]

| P910.P911_01

Standard specification

Dead weight tester

Model number		P910	P911
Range	Maximum	5 MPa	10 MPa
Range	Minimum	0.05 MPa	0.1 MPa
Minimum unit pressure		0.05 MPa	1 MPa
Area of ram		½ cm²	¼ cm²
Diameter of ram		7.979 mm	5.6420 mm
Dead-weight corresponds to (MPa)	Ram	0.05 MPa	1 pcs
		0.1 MPa	1 pcs
	Dead weight	0.05 MPa	1 pcs
		0.1 MPa	2 pcs
		0.2 MPa	1 pcs
		0.5 MPa	1 pcs
1 MPa	9 pcs		
Total		5 MPa	10 MPa
Tester	Weight	10 kg	10 kg
	Box weight	7.5 kg	7.5 kg
Ram	Weight	26 kg	26 kg
	Box weight	2.8 kg	2.8 kg

Spare parts and tool

Standard accessories	Quantity (pcs)
PF ½"	2
PF ⅜"	1
PF ¼"	1
300 mm wrench	1
250 mm wrench	1
L type union ½"	1
Packing for union	10
Packing for piston	3
Hammer	1
Pointer remover	1
Oil drum	1

Main order

Ordering information

1. Base model

P910 Dead weight tester (Calibration range: 5 MPa)

P911 Dead weight tester (Calibration range: 10 MPa)

2. Unused character

0000000000

1	2
P910	0000000000

Sample ordering code



© WISE Control Inc. All rights reserved. ALL PRODUCT, PRODUCT SPECIFICATIONS AND DATA ARE SUBJECT TO CHANGE WITHOUT NOTICE TO IMPROVE RELIABILITY, FUNCTION OR DESIGN OR OTHERWISE.

P910, P911 : Type of mounting

Code P910,P911

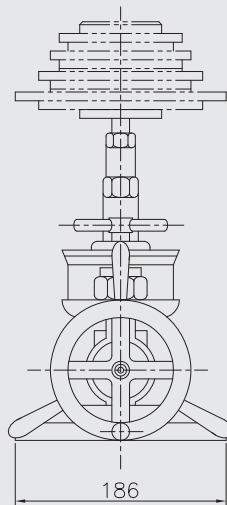
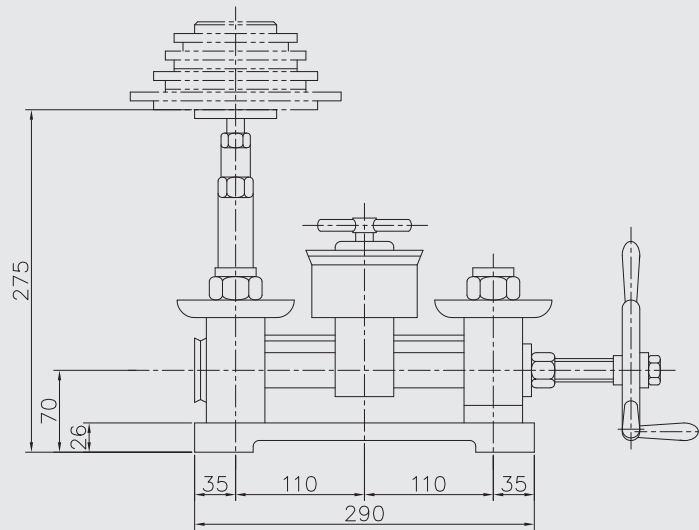

Dimensions (mm)

Available code	Range (MPa)	Increment (MPa)	Piston area (cm ²)
P910	0.05 ~ 5	0.05	1/2
P911	0.1 ~ 10	0.1	1/4

Conversion table

Pressure conversion chart

psi	atm	kgf/cm ²	inH ₂ O	mmHg	inHg	kPa	bar	mmH ₂ O
1	0.068046	0.070307	27.7276	51.715	2.03602	6.835	0.06895	704.28104
14.696	1	1.0332	407.484	760	29.921	101.325	1.01325	10350.0936
14.2233	0.96784	1	394.38	735.559	28.959	98.096	0.98067	10,000
0.036092	0.002454	0.00253	1	1.8651	0.07343	0.249	0.00249	25.4
0.019336	0.001315	0.001359	0.53616	1	0.03937	0.1333	0.001333	13.618464
0.491154	0.0033421	0.03453	13.6185	25.4	1	3.3864	0.033864	345.9099
0.145	0.00987	0.010197	4.0186	7.5006	0.2953	1	0.01	102.07244
14.5038	0.98692	1.01972	402.156	750.062	29.53	100	1	10214.7624
0.00142	0.000097	0.0001	0.03937	0.0734	0.0029	0.0098	0.000098	1

Memo